

# Accellix QC Assay

## INSTRUCTIONS FOR USE

### INTENDED USE

The Accellix QC assay is intended for routine verification of the Accellix Instrument. The fluorescent particles have a defined fluorescence intensity across all channels which are utilized to assess parameters such as optical alignment, sensitivity, linearity, and calibration of the Accellix instrument.

### ASSAY CONTENTS AND REQUIREMENTS

Assay Kit Contents	Equipment Required	Instrumentation Required
Assay reagent tube	Calibrated pipettes and tips (100–200µL)	Accellix Instrument with software version 3.8.2 and above
Assay cartridge	Pulsed vortex mixer (Scientific Industries, Vortex-Genie Pulse, SKU: SI-P236)	
	Accellix Cartridge Holder (optional)	
	Accellix Vortex Reagent Tube Adaptor Phosphate buffer saline (IX PBS), Mg <sup>2+</sup> /Ca <sup>2+</sup> free	

### ASSAY PROTOCOL

**Note:** Reagents are photosensitive. Minimize exposure to light.

1. Grip and pull the assay packaging flaps open by placing one hand on each side and pulling them apart.
2. Remove the reagent tube in the mylar pouch and the assay insert containing the cartridge from the assay packaging.
3. Remove the cartridge from the assay insert by gripping the bottom right corner of the cartridge. Avoid touching the reading channel or pressing against the assay insert as the cartridge is being removed.

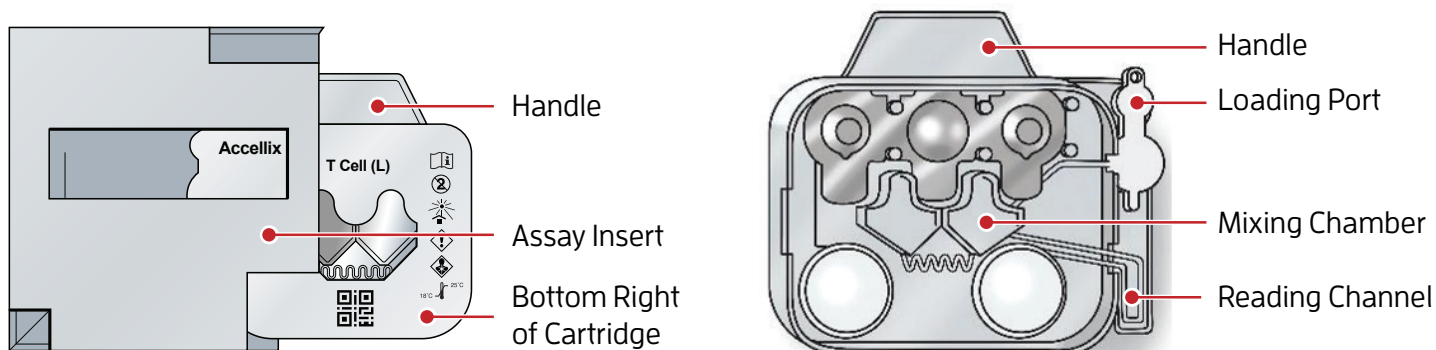

4. Place the cartridge, label-side down, on a clean surface.
5. Tear open the foil pouch and remove the reagent tube.
6. Uncap the reagent tube and accurately draw and transfer 40µl of IX PBS to the bottom of the reagent tube using a P100 or P200 pipette. Ensure not to scrape the bottom of the tube with the pipette tip.
7. Recap the reagent tube and place it in the Reagent Tube Adaptor of the preprogrammed pulsed vortex mixer. Ensure the tube is sitting vertically, not at an angle, and press 'Start'.

**Note:** The mixer is programmed to mix the reagent tube with the IX PBS for 2 minutes at 1500rpm (vortex cycle = 2 seconds on, 1 second off). For more information on how to use the vortex, see the Operating Instructions for the Vortex Genie Pulse Mixer for an Accellix Assay.

**Note:** The dried reagent at the bottom of the reagent tube must be completely dissolved for optimal assay performance.

8. After the mixing program has ended, immediately uncap the reagent tube and pipette the sample up and down 3 times using a P100 or P200 pipette. While holding the sample plug open, load 20µl of sample mixture into the loading port on the microfluidic cartridge:

- a. Firmly insert the end of the pipette tip into the hole at the bottom of the loading port, holding it at a 90-degree angle. Figure A.
- b. Depress the pipette plunger to the second stop (pushing to the second stop will move the sample into the microfluidic channel connected to the loading port). Ensure the pipette tip is fully removed from the loading port before releasing your thumb.

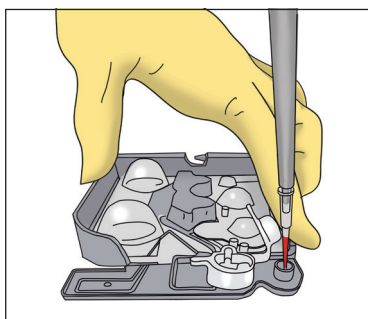

Figure A: Insert the pipette tip into the hole at the bottom of the loading port.

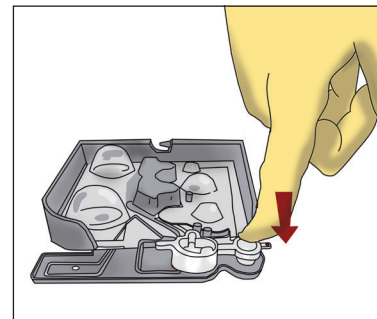



Figure B: Press the sample plug into place, covering the sample loading port.

9. With the cartridge still lying flat, firmly press the sample plug into place over the sample loading port. Figure B.
  - a. Verify that the sample fluid moved down into the channel leading to the front mixing chamber on the cartridge. Figure C.
10. Prior to opening the instrument's loading door, initiate the assay run by tapping 'Start'  on the Accellix touchscreen. Follow the on-screen instructions to proceed.

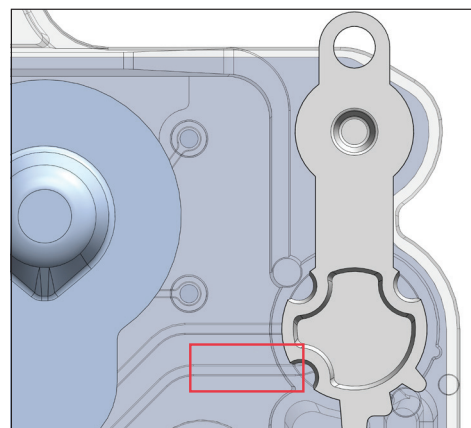

Figure C: Verify that sample fluid has moved into the microfluidic channel.

- II. Hold the cartridge by its handle with the label facing away from the operator. Insert the cartridge carefully into the cartridge slot. When a slight resistance is felt, press on the right-hand corner of the cartridge using the cartridge handle. A “click” will be heard and felt, confirming the cartridge has reached the proper position. Close the Accellix Instrument door by pressing on the curved circle on the right side of the door.
12. When prompted, enter the Sample ID using the on-screen keyboard or a barcode scanner and press ‘Next’.
13. Verify the entry and press ‘Next’.
14. The assay will then proceed automatically. Total running time, including data acquisition and analysis, is approximately 16 minutes.
15. At the conclusion of the run, follow the instructions on the screen and remove the cartridge from the Accellix Instrument.
16. The resulting data files are saved on the Accellix internal hard drive and will automatically be copied from the Accellix instrument to a storage destination configured at the time of instrument installation.



## EXPECTED RESULTS

At the end of the QC Assay run, PDF, CSV and FCS files will be generated in the results folder. The PDF and CSV files include an Accellix Results Summary as well as an Accellix QC Assay Detailed Results reporting on optical alignment, sensitivity, linearity, and calibration parameters of the Accellix Instrument.

For each parameter, the per-bead group or per-fluorescent channel results and acceptance criteria are shown in the PDF report and in the results CSV file. If a parameter’s measured value falls within acceptance criteria, “PASS” is displayed in green. If a parameter’s measured value falls outside of acceptance criteria, “FAIL” is displayed in red. The PDF report also contains relevant graphs illustrating within-run results and cumulative results over time.

**Note:** For any parameter failure please refer to the troubleshooting section below.

**Note:** For a detailed Parameter definition guide, please refer to the Accellix QC Assay Metrics below.

## FILES GENERATED AND USAGE

File Type and Name	Purpose / Usage
PDF file ending with _QC-Results	Detailed QC Assay Results Report
PDF file named Assay Results	Assay Results Summary Report
FCS ending with _Events.fcs	FCS for Accellix Troubleshooting
CSV file ending with _Events	CSV for Accellix Troubleshooting
CSV file ending with _QC-Results	CSV for plotting trends over time

## ACCELLIX QC ASSAY METRICS

**Bead Count:** The bead count for each group is reported to ensure that there are sufficient events detected for statistically robust measurements of Forward Scatter (FSC) and Median Fluorescence Intensity (MFI).

**Linearity:** Linear regression analysis characterizes the correlation between six bead fluorescence intensity levels (groups 1-6) in each optical channel and the expected molecules of equivalent fluorochrome (MEFL). The correlation coefficient (R2 value) is reported as an indicator of detector linearity.

## SENSITIVITY

**Stain Index:** The stain index (SI), or the separation between the dimmest bead group and the blank bead group in each fluorescent channel, is an indicator of instrument sensitivity. Stain index is defined as:

$(\text{MFI of Dimmest Positive Group} - \text{MFI of Blank Group}) / (2 \times \text{rSD of Blank Group in same channel}) = \text{Stain Index}$

**% CV:** The coefficient of variation (CV) of MFI and FSC signals in their respective channels is another indicator of instrument sensitivity and is defined as the robust standard deviation of the signal divided by the median of that signal.

**Calibration:** The QC Assay contains the same beads (group 7) that are used to calibrate the voltages for each detector channel. The percent difference between the bead MFI in each channel relative to the target MFI used during calibration is reported as a way to verify that the instrument remains calibrated.

**Results Summary:** A table showing summarized results for bead count, optical linearity, sensitivity, and calibration is displayed on-screen at the completion of the run and in the PDF report. It indicates overall pass/fail for each of the four parameters and provides instructions in the case that the assay fails.

**Detailed Results:** For each parameter, the per-bead group or per-fluorescent channel results and acceptance criteria are shown in the PDF report and in the results CSV file. If a parameter's measured value falls within acceptance criteria, "PASS" is displayed. If a parameter falls outside of acceptance criteria, "FAIL" is displayed. The PDF report also contains relevant graphs illustrating within-run results and cumulative results over time.

## STORAGE, STABILITY AND DISPOSAL

1. Store Accellix Assays at room temperature (15-25°C) in their original packaging until ready for use.
2. Reagents are photo sensitive. Minimize exposure to light.
3. Accellix Assays are valid for use until the expiration date printed on the cartridge next to the hourglass icon and on the box.
4. Samples, used cartridges, and reagent tubes should be disposed of with proper biohazard precautions in accordance with local regulations.

## WARNINGS AND PRECAUTIONS

1. Accellix Assays are not intended for diagnosis of human or animal disease.
2. For professional use only.
3. Follow standard laboratory safety precautions when handling the Accellix Assays. Safety datasheets are available upon request.
4. Do not use a damaged cartridge, reagent tube, or Accellix Assay with damaged packaging.
5. Do not use an expired cartridge or tube. The expiration date is located on the assay packaging and component labels.
6. Do not re-use a cartridge.
7. Do not open the instrument door when an assay is in progress, as this will abort the assay and the cartridge cannot be reused.

## TROUBLESHOOTING

1. If an error is displayed on the screen of the Accellix Instrument at any point during a run, follow the instructions displayed. Please keep the cartridges in which the error occurred or take a picture of the front and back of the cartridge to share with Accellix Support.
2. If a failure occurs, or if the screen instructs to contact Accellix Support, contact:

Accellix, Inc.  
2385 Bering Drive  
San Jose, CA 95131  
email: [support@accellix.com](mailto:support@accellix.com)

---

## HAZARD PICTOGRAMS



Signal Word:

Danger

Hazard Statement:

H332 - Harmful if inhaled.

H317 - May cause an allergic skin reaction.

H350 - May cause cancer.

H341 - Suspected of causing genetic defects.

## PRECAUTIONARY STATEMENTS

### Prevention:

P202 - Do not handle until all safety precautions have been read and understood.

P280 - Wear protective gloves. Wear eye or face protection. Wear protective clothing.

P261 - Avoid breathing vapor.

P272 (OSHA) - Contaminated work clothing must not be allowed out of the workplace.

### Response:

P308 + P313 – IF EXPOSED: Get medical attention.

P304 + P340 + P312 - IF INHALED: Remove person to fresh air and keep comfortable for breathing. Call a POISON CENTER or physician if you feel unwell.

P302 + P352 + P363 - IF ON SKIN: Wash with plenty of soap and water. Wash contaminated clothing before reuse.

P333 + P313 - If skin irritation or rash occurs: Get medical attention.

This assay contains products of animal origin. Certified knowledge of the origin and/or sanitary state of the animals does not totally guarantee the absence of transmissible pathogenic agents. It is therefore recommended that these products be treated as potentially infectious and handled observing the usual safety precautions (do not ingest; do not inhale).

To learn more about the Accellix Cell Phenotyping Platform, email us at [info@accellix.com](mailto:info@accellix.com)

